

robot coupe[®]

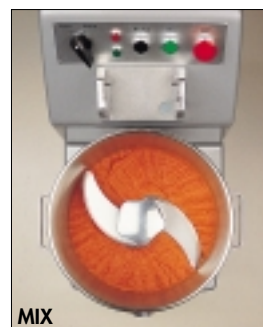

R 20 • R 25 • R 25B • R 40 • R 40B • R 60B
VERTICAL CUTTERS MIXERS

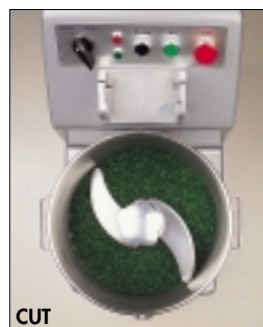

INSTITUTIONS - DELICATESSENS - CATERERS - RESTAURANTS - CONFECTIONERS

R 20



- 17.5 litre stainless steel bowl designed to be simple to use and clean.
- See through cap constructed in high impact, heat resistant polycarbonate. Liquids can be added while processing.
- Lid specially designed with anti-drip system to prevent spillage.
- Perfect lid sealing. Opening and closing only requires one simple operation.
- Patented knife gives perfect result for small or large quantities.
- Central bowl hub allows maximum processing of liquids.
- Mechanical safety system and motor brake prevent the machine being used when the lid is not properly locked. Machine and blade stop as soon as the lid is open.
- All electrical parts are water-protected for easy cleaning.
- Options : vacuum kit and/or double jacket bowl.
- The **R20 V.V.** has different speed variation from 50 to 3000 Rpm which gives maximum versatility of use and allows a growing number of food preparation thanks to an additional function at low speed: the mixing.

R 25 • R 40



- 25 or 36 litre stainless steel bowl depending on model.
- Available with tilting or non-tilting bowl.
- Tilting function speeds production.
- Simple assembly.
- Removable and adjustable blades.
- A scampa knife especially designed for volum meat processing.
- Kneading tool for large quantities of yeast doughs.
- All parts in contact with food are easy to clean.
- For each model, a double jacket bowl to cool, warm or maintain temperature of processed ingredients is available as an option.
- New locking system on lid for easy handling.
- Safety system on lid and motor brake to stop the blade as soon as the lid is open.
- Magnetic bowl detection safety device.

R 60B



- All stainless steel construction with a 60 litre capacity bowl.
- Robot-Coupe patented knife design gives perfect results to processed ingredients.
- Perfectly conceived for all chopping, mixing, kneading and blending tasks or homogenization in all different fields such as delicatessens, caterers, institutions and laboratories...
- New locking system on lid for easy handling.
- Safety system on lid and motor brake to prevent any access to the blade when moving.
- Magnetic bowl detection safety device.
- All electrical parts are water-protected for easy cleaning.
- Motor power : 6600/9600 HP.

VCM food processors with 20 to 60 litre bowl capacities covering every size and type of establishment - restaurant to food manufacturer. The VCM range provides even more evidence of Robot Coupe's reputation among professionals as the true leaders and originators of food processors. Each model allows you to retain the precise control needed to achieve individual results. The results which make all the difference to your final profits. Robot Coupe's achievement in VCM food processing is based on technical innovation and excellence. Just look at these features.

- Adjustable blades to handle small or large quantities
- Bowls and all other parts in contact with food removable for easy cleaning
- All models incorporate no volt release, motor brake, lid security and 2 speeds 1 500 and 3 000 Rpm.

Mix pastry in 20 seconds. Mix and knead dough in less than 2 min. Make a bowlful of mayonnaise in 1 minute. Fine chop parsley, meats or vegetables in seconds.

CHOP	EMULSIFY	KNEAD	GRIND
Hamburgers, tartare, sausagemeat, terrine, pâté, groundmeat, garlic, parsley, onions, shallots, purées, compotes...	Liver mousse, fish mousse, galantine, white pudding, brandade, quenelles, anchovie or, salmon butter, mayonnaise, sauces...	Sweet pastry, short crust pastry, Croissants pastry, Chou pastry, bread dough, madeleine cakes, muffins, scones, brioche...	Fruits, seashells, breadcrumbs, ice cube, almonds, nuts, raw almond paste, praline, pure hazelnut paste, icing sugar...

Floor standing VCM's are high speed and versatile food mixers. Robot-Coupe offers a unique range with bowl capacity from 17.5 to 60 litres, all of them with 2 speeds for the perfect control over the processing, from **300 g. up to 30 kg** at a time.

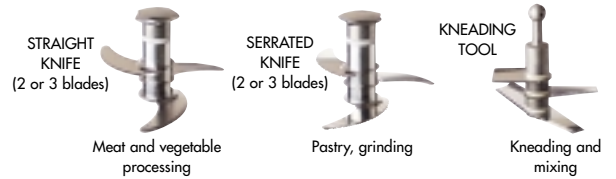

MODELS	NUMBER OF COVERS	MAX. PROCESSING CAPACITY
R20	from 50 to 300	8 kg
R25/B	from 100 to 500	12 kg
R40/B	from 200 to 800	18 kg
R60/B	more than 500	30 kg

Processing time : 1-4 minutes depending on type of food preparation



VACUUM CUTTER MIXERS



The ROBOT-COUPÉ vacuum cutter mixers are equipped with a vacuum kit **R-VAC®**, patented by ROBOT-COUPÉ.

This kit is very simple to attach to the lid and to connect to a independent vacuum pump or to a vacuum packing machine.

It allows liquids to be added while processing.

Equipped with adjustable blades to process small or large quantities, vacuum cutters ensure :

- **thorough mixing**
- **perfect cut**
- **consistant quality**
- **better hygiene.**

Vacuum processing allows you to obtain better results by giving :

- **longer shelf life**
- **retention of flavors**
- **fresh presentation.**

The "sous-vide" vacuum cutters have applications : in the **food sector** for foie gras, liver or fish terrine, galantine, white pudding or sausage...; in **pharmaceutical** and cosmetic laboratories for base preparations with creams, powders...

The **R-VAC®** can be fitted as an additional attachment to the models R10 and R20.

TECHNICAL SPECIFICATIONS

Electrical data

Models	Motor	Rpm	Rpm	Input power in watts	Amp.
R 20	230 x 400 V/50 Hz commutable	1500	3 000	3 300	230V 18,3
					400V 10,5
	400 V/50 Hz	1500	3 000	4 400	230V 19,8
					400V 11,4
	220 V/60 Hz	1800	3 600	4 400	3 300
					7,8
R 25/ R 25B	230 x 400 V/50 Hz commutable	1500	3 000	3 500	230V 18,2
					400V 10,6
	400 V/50 Hz	1500	3 000	4 500	230V 18,5
					400V 10,7
	220 V/60 Hz	1800	3 600	4 500	3 500
					8,6
					10,6
					15,0
R 40/ R 40B	230 x 400 V/50 Hz commutable	1500	3 000	5 100	230V 23,6
					400V 13,6
	400 V/50 Hz	1500	3 000	6 600	230V 24,0
					400V 13,8
	220 V/60 Hz	1800	3 600	6 600	5 150
					12,2
					14,7
					21,2
					24,9
R 60B	230 x 400 V/50 Hz commutable	1500	3 000	6 600	230V 29,0
					400V 16,8
	400 V/50 Hz	1500	3 000	8 100	230V 30,0
					400V 17,3
	220 V/60 Hz	1800	3 600	9 600	6 600
					19,5
					31,7
					26,4
					38,0

Weight

R20	Net weight	75 kg	Gross weight	88 kg
R25	Net weight	85 kg	Gross weight	100 kg
R25B	Net weight	116 kg	Gross weight	131 kg
R40	Net weight	125 kg	Gross weight	141 kg
R40B	Net weight	149 kg	Gross weight	165 kg
R60B	Net weight	250 kg	Gross weight	301 kg

Dimensions (in mm)

R20
A 705
B 635
C 375

R25
A 875
B 720
C 420

R40
A 1000
B 720
C 420

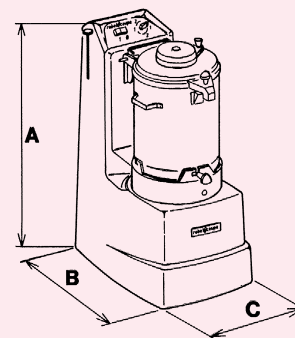

R25B
A 1050
B 880
C 550
D 335
E 1510
F 630

R40B
A 1250
B 880
C 550
D 340
E 1730
F 820

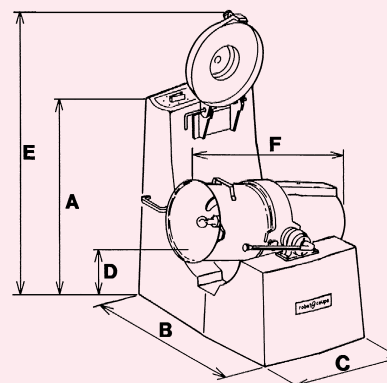

R60B
A 1245
B 830
C 1060
D 330
E 1940
F 960

R60B
A 1245
B 830
C 1060
D 330
E 1940
F 960

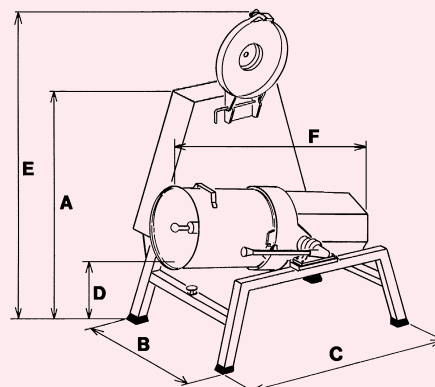

STANDARDS : MACHINES IN COMPLIANCE WITH :

- Is in conformity with the following directives and with standards and relations regarding safety and hygiene: 89/392/CEE, 73/23/CEE, 89/336/CEE, 89/109/CEE, 90/128/CEE.
- Is in conformity with the following European Harmonised Standards: EN 292 - 1 and - 2, EN 60204 - 1 (1992), EN 12852.
- INDEXES OF PROTECTION: • IP 65 for the switches. • IP 34 for the machines.

MADE IN FRANCE BY ROBOT-COUPÉ S.N.C.

Head Office, French, Export and Marketing Department:

Tel.: + 33 1 43 98 88 33 - Fax: + 33 1 43 74 36 26 - <http://www.robot-coupe.fr>
18, rue Clément Viénot - BP 157 - 94305 Vincennes Cedex - France

Robot-Coupe Australia: Tel.: (02) 9958 0853 - Fax: (02) 9958-0867

P.O. Box 146 - Northbridge NSW 1560

Robot-Coupe U.K. LTD: Tel.: 020 8232 1800 - Fax: 020 8568 4966

2, Fleming Way, Isleworth, Middlesex TW7 6EU

Robot-Coupe U.S.A.: Ph.: 1-800-824-1646 - Fax: 601-898-9134

P.O. Box 16625 - Jackson, Mississippi 39236-6625

DISTRIBUTOR

robot coupe

We reserve the right to alter at any time without notice the technical specifications of this appliance.
None of the information contained in this document is of a contractual nature. Modifications may be made at any time.
© All rights reserved for all countries by: ROBOT-COUPÉ S.N.C.